

LDM030/060/100

Introduction

The newest generation of Laser distance measurement modules offers measuring ranges from 30 up to 100 meters. The LDK Model 2 series are compact units with small dimensions: only 37.5 x 45.3 x 19.2 mm. They are designed for users to easily connect the Laser measurement unit to a PC or an MCU through RS232 communication (UART TTL). A Bluetooth option is also available, please refer to the Egismos Laser Distance measuring BT-series. The unit has a 1mm resolution and an accuracy of $\pm 3.0\text{mm}$ along with a high sampling rate (up to 10 samples / second)

The typical UART output uses a serial RS232 with standard communication transmission protocol, which is the most common configuration for PC serial communications today. The common line speed has a Baud Rate of 9600.



Features

- * Distance measuring capacity.
- * RS-232 serial port connectivity.
- * Compact dimensions: 37.5 x 45.3 x 19.2 mm.
- * option Bluetooth module for wireless applications

Specifications (T=25°C)

Items			
Model Name	LDM030	LDM060	LDM100
Measuring Range	0.06 ~ 30 meters	0.06 ~ 60 meters	0.06 ~ 100 meters
Measure Accuracy	± 3.0 mm @ 25°C		
Measure Rate	1 ~ 10 Hz		
Mechanical Dimension	37.5 x 45.3 x 19.2 mm		
Distance Resolution	1 mm		
Starting Current	Min. 300mA, Typ. 500mA		
Operating Current	<200 mA		
Operating Voltage(DC)	2.5 ~ 3.0 V		
Transmission Mode	RS-232 TTL (UART)		
Transmission Interfaces	Female USB "B" connector		
Baud Rate	9600		
Operating Temperature	0 ~ 50 °C		
Storage Temperature	-20 ~ 70 °C		
Buzzer Sound	60 ± 20 dB		
Laser Beam Size	2.5 x 5 mm @ 3 meter (FWHM)		
Laser Wavelength	620~690 nm		
Laser Safety	<1 mW (Class 2)		
EMC Protection	Class A		

Pin Assignment

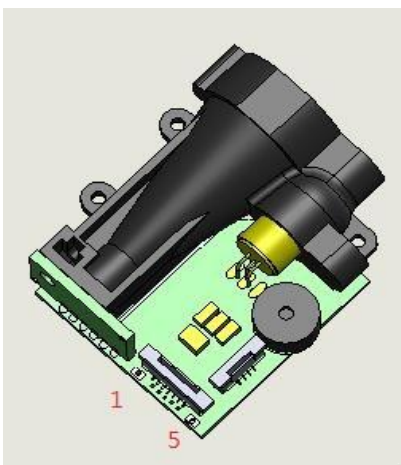

1. Vin : Vcc
2. Vur : UART Rx, TTL level
3. Vut : UART Tx, TTL level
4. Vpe : Power Enable, used for system ON (High) and OFF(Low) or can be used as Reset pin
5. GND : Ground

Outline Dimensions

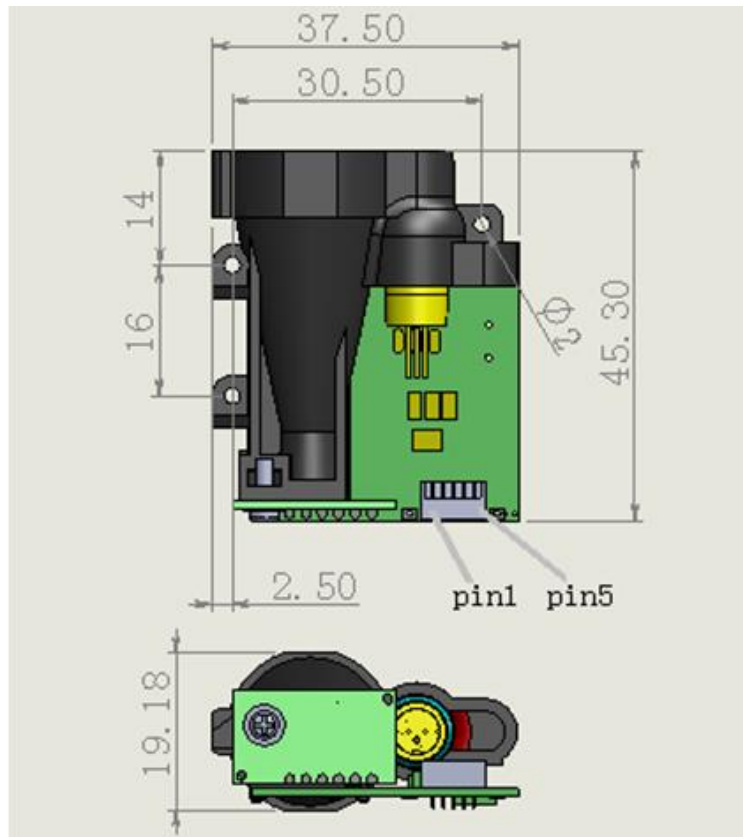

Electrical Characteristics

Value	Symbol	Min	Typical	Max	Unit
Voltage Input	V _{in}	2.5	3.0	3.1	V
Current Input	I _{in}	300	500	-	mA
UART Rx Logic 1	V _{uth}	3.0	3.3	3.4	V
UART Rx Logic 0	V _{utl}	-0.3	0	0.8	V
UART Tx Logic 1	V _{urh}	3.0	3.3	3.4	V
UART Tx Logic 0	V _{url}	-0.3	0	0.3	V
Power Enable Logic 1	V _{peh}	3.0	3.3	V _{in} +0.3	V
Power Enable Logic 0	V _{pel}	-0.3	0	0.1	V

Connection

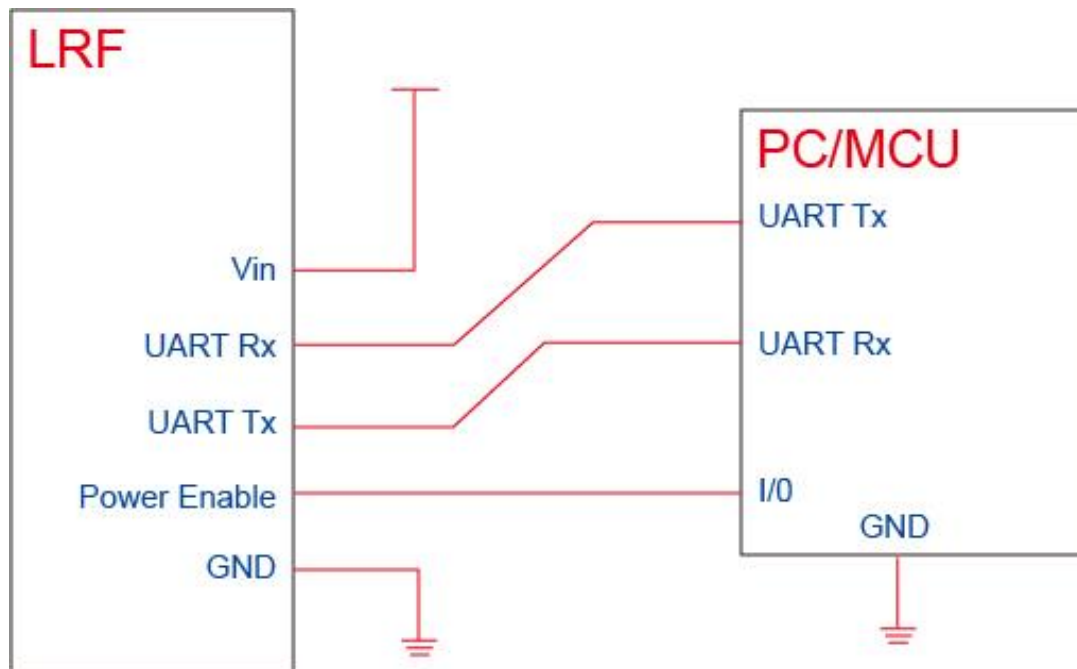

Note

Users should check their OS version (Operating System) to confirm that RS232 data transmission is available.

Communication Format

Master (PC/MCU) Read/Write							
Initiate	Address	Command	Data 1	Data N	Check Sum	End
1 Byte	1 Byte	1 Byte	1 Byte	1 Byte	1 Byte	1 Byte	1 Byte
Slave (Laser Distance Measuring Kit)							
Initiate	Address	Command	Data 1	Data N	Check Sum	End
1 Byte	1 Byte	1 Byte	1 Byte	1 Byte	1 Byte	1 Byte	1 Byte

Initiate: 0xAA

End: 0xA8

Address: 0 is the master, 1-127 are the slave/devices on the Bus.

The master can communicate with all the slave devices on the Bus

Data: Some commands may have no response

Checksum: Only Bit 7 to avoid conflict with Initiate or End. The highest level is set at 0.

Checksum = (Address+Command+Data 1+...+Data n) & 0x7F.

Commands

	Remark
0x01	Read Software version
0x02	Read Device Type
0x04	Read slave address
0x41	Set Slave address
0x08	Read device error code
0x42	Laser ON
0x43	Laser OFF
0x44	Single measurement
0x45	Continuous measurement
0x46	Stop continuous measurement

Commands details (Set slave as 0x01)

Read SW version						
Master	Initiate	Address	Command	CheckSum	End	
	0xAA	0x00	0x01	0x01	0xA8	
Slave	Initiate	Address	Command	Data 1	Data 2	Data 3
	0xAA	0x01	0x01	0x28	0x48	0x4D
	Data 4	Data 5	Data 6	Data 7	Data 8	Data 9
	0x53	0x44	0x33	0x30	0x2D	0x33
	Data 10	Data 11	CheckSum	End		
	0x30	0x29	0x72	0xA8		

※Slave response Version hex display (HMSD30-30),The corresponding model is LDM030

Read SW version						
Master	Initiate	Address	Command	CheckSum	End	
	0xAA	0x00	0x01	0x01	0xA8	
Slave	Initiate	Address	Command	Data 1	Data 2	Data 3
	0xAA	0x01	0x01	0x28	0x48	0x4D
	Data 4	Data 5	Data 6	Data 7	Data 8	Data 9
	0x53	0x44	0x36	0x30	0x2D	0x33
	Data 10	Data 11	CheckSum	End		
	0x30	0x29	0x75	0xA8		

※Slave response Version hex display (HMSD60-30), The corresponding model is LDM060

Read SW version						
Master	Initiate	Address	Command	CheckSum	End	
	0xAA	0x00	0x01	0x01	0xA8	
Slave	Initiate	Address	Command	Data 1	Data 2	Data 3
	0xAA	0x01	0x01	0x28	0x48	0x4D
	Data 4	Data 5	Data 6	Data 7	Data 8	Data 9
	0x53	0x44	0x31	0x30	0x30	0x2D
	Data 10	Data 11	Data 12	CheckSum	End	
	0x33	0x30	0x29	0x20	0xA8	

※Slave response Version hex display (HMSD100-30), The corresponding model is LDM100

Read Device Type						
Master	Initiate	Address	Command	CheckSum	End	
	0xAA	0x01	0x02	0x03	0xA8	
Slave	Initiate	Address	Command	Data 1	CheckSum	End
	0xAA	0x01	0x02	0x01	0x04	0xA8

※Slave response: Device type is LFR

Read Device status						
Master	Initiate	Address	Command	CheckSum	End	
	0xAA	0x01	0x08	0x09	0xA8	
Slave	Initiate	Address	Command	Data 1	CheckSum	End
	0xAA	0x01	0x08	0x00	0x09	0xA8

※Slave response: 0x00 as Not ready yet; 0x01 as Standby; 0x31 as Error.

When an error message is displayed, we suggest to the user to reset the system by following the procedure below:
set the Power Enable pin level low for 200ms and then back high, and check if the system works.

If not, please contact Egismos for further service.

Read Slave Address						
Master	Initiate	Address	Command	CheckSum	End	
	0xAA	0x00	0x04	0x04	0xA8	
Slave	Initiate	Address	Command	Data 1	CheckSum	End
	0xAA	0x01	0x04	0x01	0x06	0xA8

※Slave response: Address is 0x01

Set Slave Address						
Master	Initiate	Address	Command	Data 1	CheckSum	End
	0xAA	0x00	0x041	0x02	0x43	0xA8
Slave	Initiate	Address	Command	Data 1	CheckSum	End
	0xAA	0x02	0x041	0x01	0x44	0xA8

※Master command: Set slave Address as 0x02; Slave response: 1-Success, 0-Failed

Laser ON						
Master	Initiate	Address	Command	CheckSum	End	
	0xAA	0x01	0x42	0x43	0xA8	
Slave	Initiate	Address	Command	Data 1	CheckSum	End
	0xAA	0x01	0x42	0x01	0x44	0xA8

※ This Command is for user to easily aim at the target, but is not a necessary procedure for the measurement

※ Slave response: 1-Success, 0-failed

Laser OFF						
Master	Initiate	Address	Command	CheckSum	End	
	0xAA	0x01	0x43	0x44	0xA8	
Slave	Initiate	Address	Command	Data 1	CheckSum	End
	0xAA	0x01	0x43	0x01	0x45	0xA8

※ Slave response: 1-Success, 0-failed

Single measurement											
Master	Initiate	Address	Command	CheckSum	End						
	0xAA	0x01	0x44	0x45	0xA8						
Slave	Initiate	Address	Command	Data1	Data2	Data3	Data4	Data5	Data6	Check Sum	End
Cond.1	0xAA	0x01	0x44	0x30'0'	0x32'2'	0x33'3'	0x34'4'	0x35'5'	0x36'6'	0x79	0xA8
Cond.2	0xAA	0x01	0x44	0x45'E'	0x52'R'	0x52'R'	0x32'2'	0x35'5'	0x35'5'	0x74	0xA8

※ 1. Slave response: Data Byte coding with ASCII.

Continuous Measurement											
Master	Initiate	Address	Command	CheckSum	End						
	0xAA	0x01	0x45	0x46	0xA8						
Slave	Initiate	Address	Command	Data 1	Data2	Data3	Data4	Data5	Data6	Check Sum	End
Cond.1	0xAA	0x01	0x45	0x30'0'	0x32'2'	0x33'3'	0x34'4'	0x35'5'	0x36'6'	0x7A	0xA8
Cond.2	0xAA	0x01	0x45	0x45'E'	0x52'R'	0x52'R'	0x32'2'	0x35'5'	0x35'5'	0x75	0xA8

※The Continuous measurement command allows the Laser Distance Measuring kit to feedback measurement data continuously.

There are 2 ways to stop the continuous mode: 1. STOP Continuous measurement command, and 2: Level Low the supply power, such as system OFF.

※The slave response is shown above.

For example: If the measuring distance is 23.456m, Data will be shown as above Cond.1;

but if the system fails, the error code will be 255, the response data will be shown as Cond. 2, other error codes will display "ERRxxx".

Error code	Problem	Description
ERR204	calculate error	The Target moved too fast
ERR255	Weak signal reception	Use a reflective film on the target, or find a more adapted measurement point on the target
ERR256	Strong signal reception	Use a reflective film on the target, or move the target away from any light source.

STOP Continuous Measurement

Master	Initiate	Address	Command	CheckSum	End	
	0xAA	0x01	0x46	0x47	0xA8	
Slave	Initiate	Address	Command	Data 1	CheckSum	End
	0xAA	0x01	0x46	0x01	0x48	0xA8

※Slave response: 1-Success, 0-failed

ON/OFF Buzzer

Master	Initiate	Address	Command	Data 1	CheckSum	End
	0xAA	0x01	0x47	0x01	0x49	0xA8
Slave	Initiate	Address	Command	Data 1	CheckSum	End
	0xAA	0x01	0x47	0x01	0x49	0xA8

※Users can use this command to turn ON or OFF the Buzzer on the Laser Distance measuring kit by sending 0 for OFF or 1 for ON . The example above shows a command to turn the Buzzer ON, and Slave response is: 1-Success, 0-failed.

Notice

1. User should always remember to turn OFF the power of the Laser Distance Measuring Kit when the measurement is complete, as keeping the power on might reduce the life-time of the Laser and of the light receiving element inside the Laser Distance Measuring Kit.
2. Resistors of a few hundred Ohm are preferentially added between the pins UART Rx, UART Tx and the user's MCU in order to limit the voltage discrepancy between the two systems that would lead to current loss.
3. Measure Accuracy ± 3.0 mm @ 25°C, room environment.
The outdoor measurement accuracy can be roughly calculated using the following formula.
Accuracy reference (mm) = (L-20) x C x 0.3 +2
L: measure distance (M), C: constant=1
4. The measure rate changes automatically based on reflectance and environmental conditions.
5. Continuous testing at low temperatures(0°C) should not exceed 30 minutes.
6. Measurement targets should avoid direct light exposure.